

Straight-Line Rettungszeichenleuchten
SNP 1520 / SNP 1530



Rettungszeichenleuchten zum Anschluss an 230V-Gruppen- und Zentralbatterie-Anlagen oder 24V-Sicherheitsstromversorgungsanlagen nach DIN VDE 0108 und EN 50171. Ausführung gem. DIN EN 1838 und DIN EN 60598-2-22. Funkentstörung gem. DIN EN 55015.

Technische Daten

- Anschlussspannung:** siehe Typenschild
- Zul. Temp. Bereich:** -15 ...+40°C
- Anschlussklemmen:** 2 x 2,5 mm²
- Schutzklasse:** siehe Typenschild
- Schutzart:** IP 40
- Leuchtmittel:** LEDs

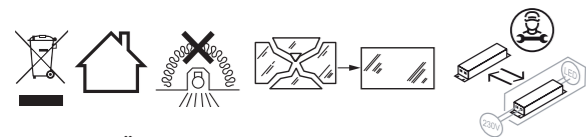

Technische Änderungen vorbehalten!

Operating Instruction

Straight-Line Exit-luminaires
SNP 1520 / SNP 1530



Exit-luminaires for connection to 230V group- or central battery systems according to DIN VDE 0108 and EN 50171 and 24V Safety Power Supply systems. Design according to DIN EN 1838 and DIN EN 60598-2-22. Radio interference according to DIN EN 55015.

Technical data

- Rated voltage:** see typ label
- Temp. range:** -15 ...+40°C
- Terminals:** 2 x 2,5 mm²
- Protection class:** see typ label
- Protection category:** IP 40
- Illuminant:** LEDs

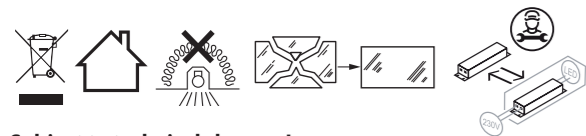

Subject to technical changes!

Parallele Wandmontage Parallel to wall mounting

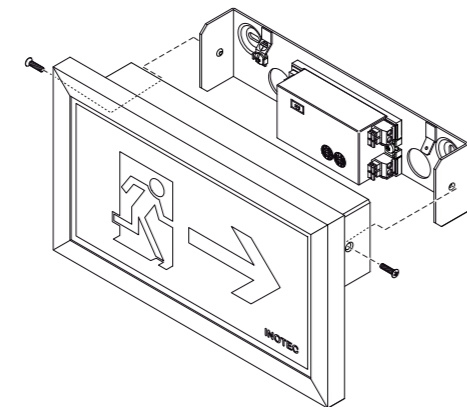

Wandeinbaumontage Recessed wall mounting

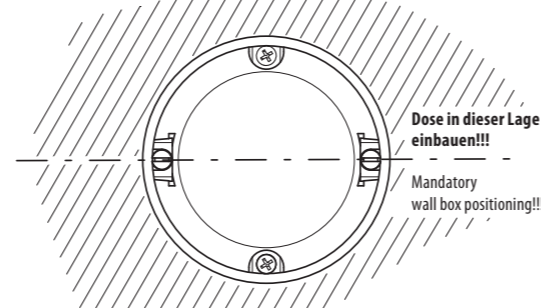
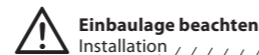
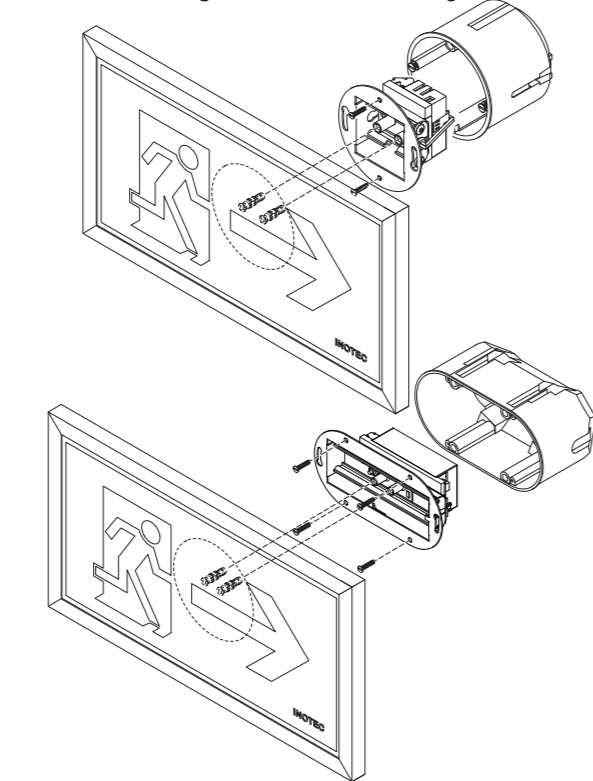

Polung beachten!
Check polarity!

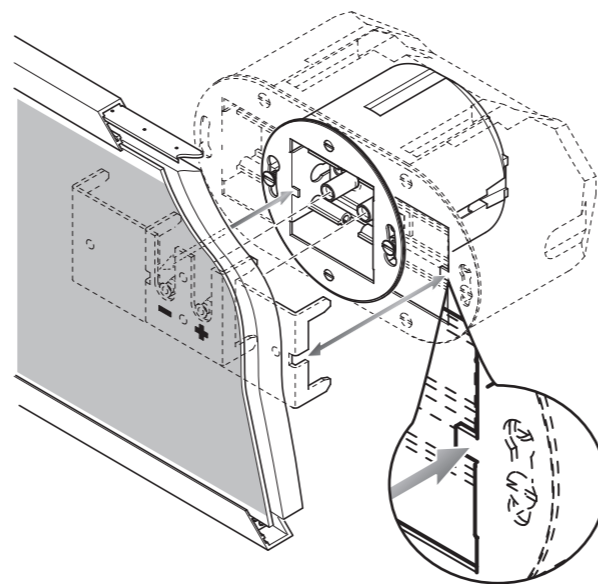

SNP 1520 24V
Wandeinbaumontage Recessed wall mounting

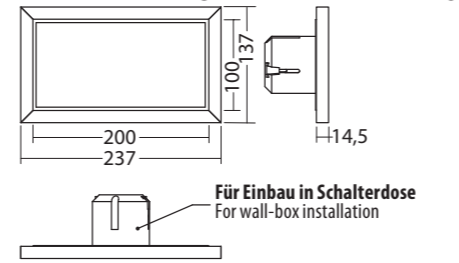

SNP 1530 24V
Wandeinbaumontage Recessed wall mounting

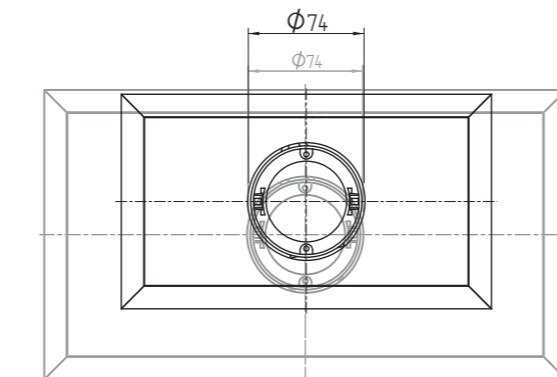
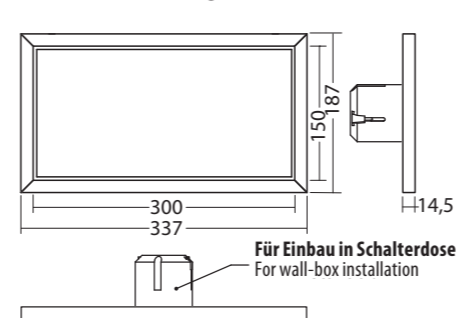

SNP 1520 230V
Wandeinbaumontage Recessed wall mounting

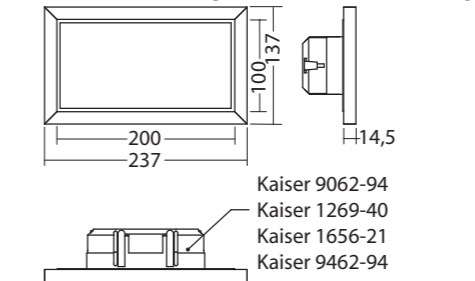

SNP 1530 230V
Wandeinbaumontage Recessed wall mounting

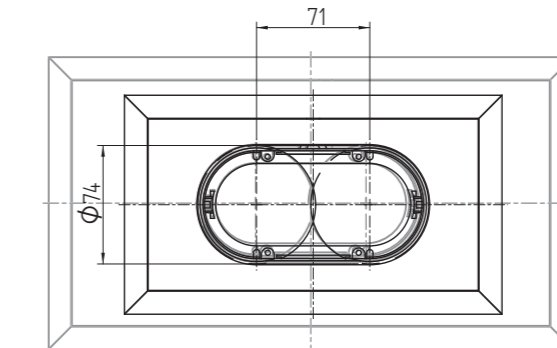
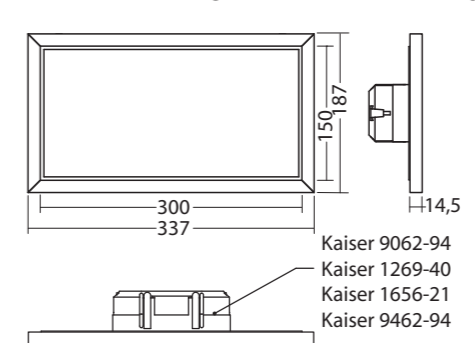

SNP 1520 E 230V
SNP 1520 E 24V
Deckeneinbaumontage Recessed ceiling mounting

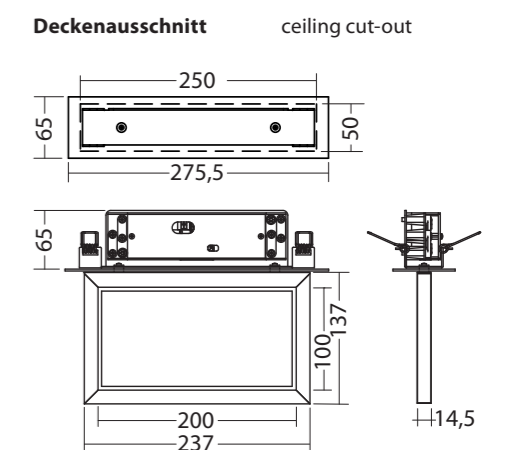

SNP 1530 E 230V
SNP 1530 E 24V
Deckeneinbaumontage Recessed ceiling mounting

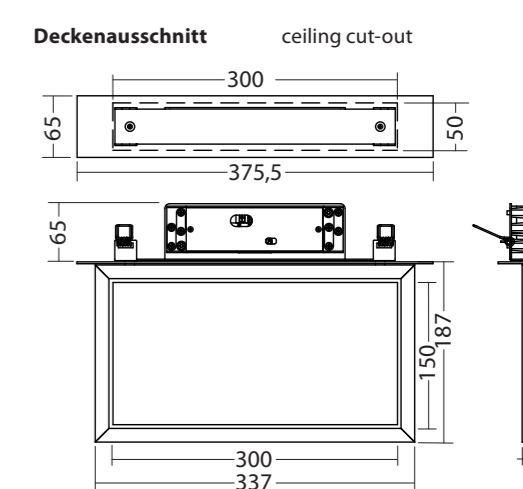

Montageanleitung

INOTEC
Sicherheitstechnik GmbH

SNP 1520 24V

- Deckenmontage** Ceiling mounting
- Pendelmontage** Pendulum mounting
- Seilmontage** Cable mounting

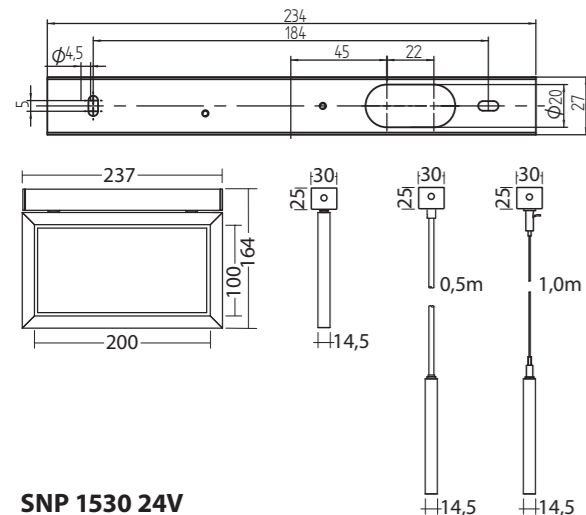

SNP 1530 24V

- Deckenmontage** Ceiling mounting
- Pendelmontage** Pendulum mounting
- Seilmontage** Cable mounting

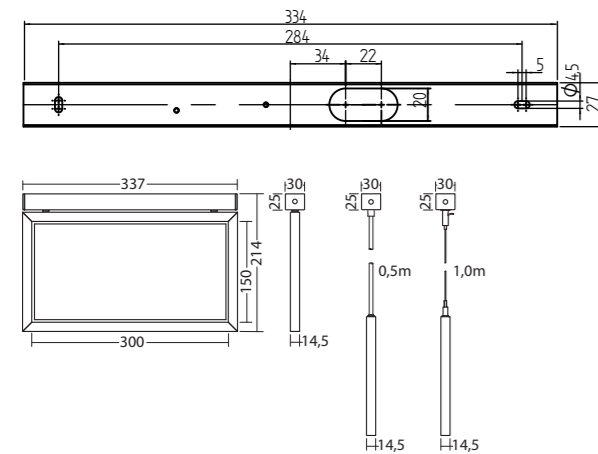

Mounting instruction

INOTEC
Sicherheitstechnik GmbH

SNP 1520 230V

- Deckenmontage** Ceiling mounting
- Pendelmontage** Pendulum mounting
- Seilmontage** Cable mounting

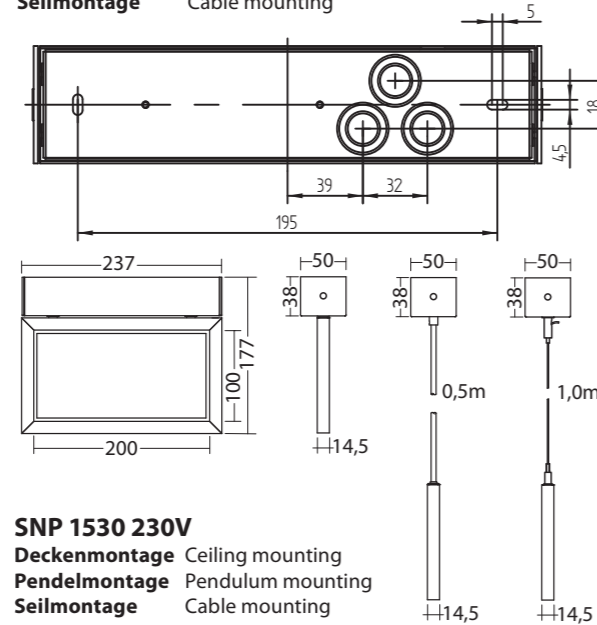

SNP 1530 230V

- Deckenmontage** Ceiling mounting
- Pendelmontage** Pendulum mounting
- Seilmontage** Cable mounting

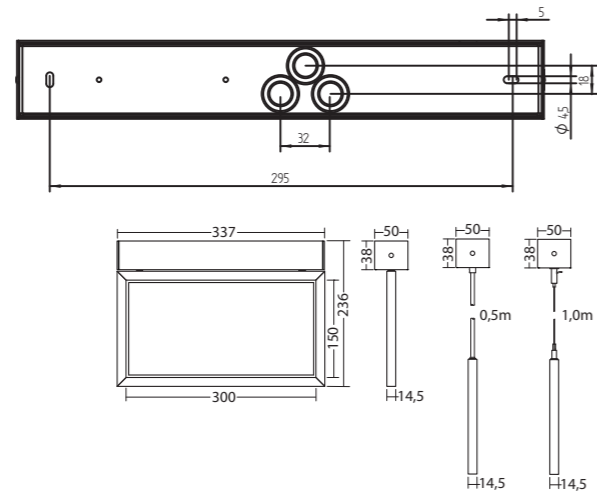

Montageanleitung

INOTEC
Sicherheitstechnik GmbH

SNP 1520 24V

- Parallele Wandmontage** Parallel to wall mounting

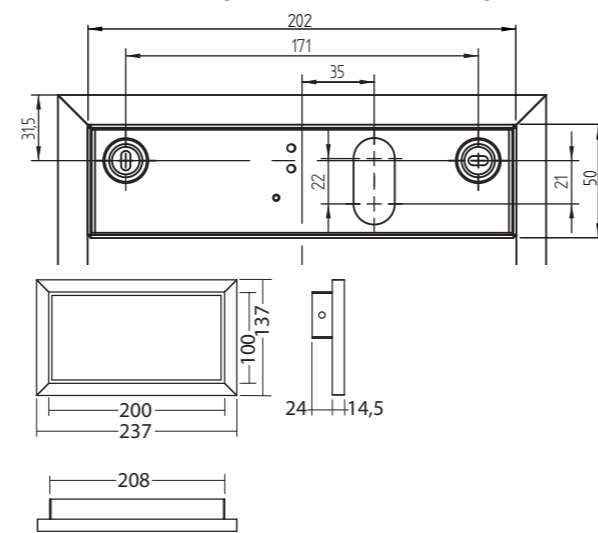

SNP 1530 24V

- Parallele Wandmontage** Parallel to wall mounting

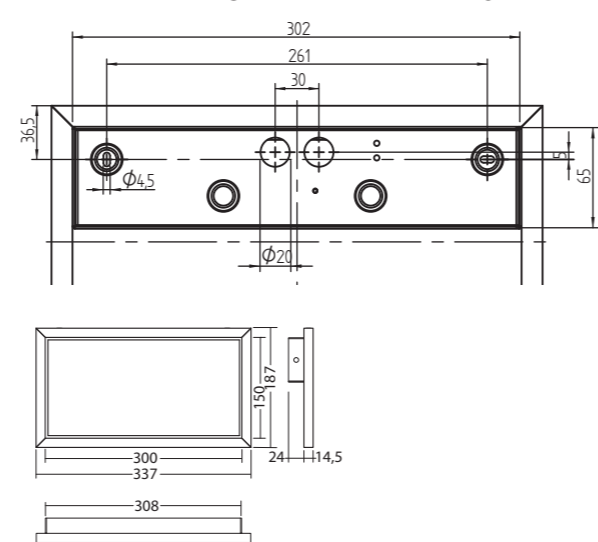

Mounting instruction

INOTEC
Sicherheitstechnik GmbH

SNP 1520 230V

- Parallele Wandmontage** Parallel to wall mounting

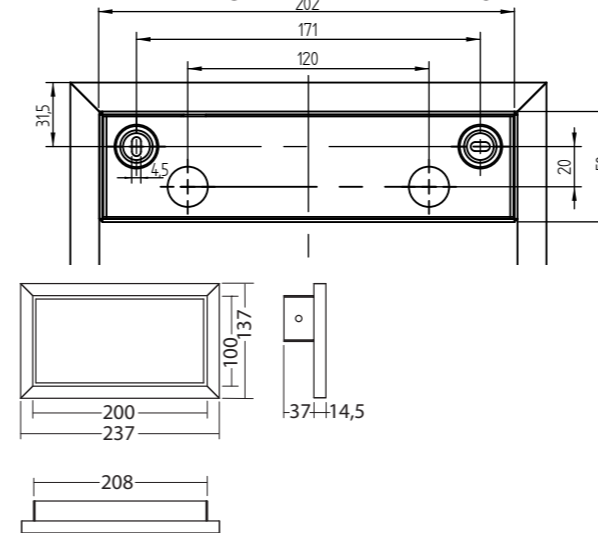

SNP 1530 230V

- Parallele Wandmontage** Parallel to wall mounting

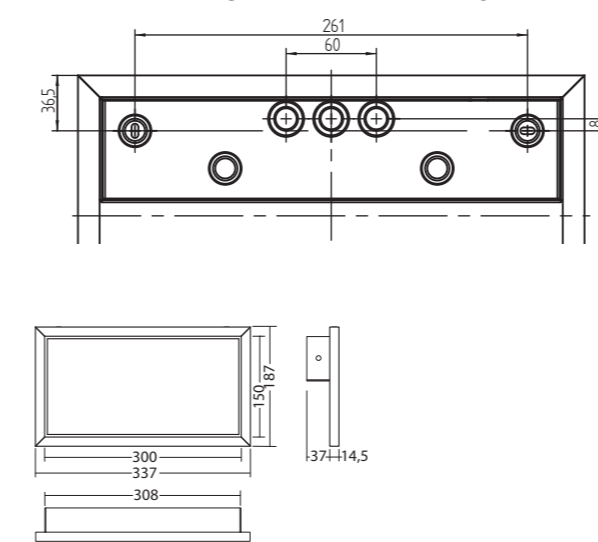

Montageanleitung

INOTEC
Sicherheitstechnik GmbH

Mounting instruction

INOTEC
Sicherheitstechnik GmbH

Bei Pendel- und Seilmontage Polung beachten!
Check polarity at cable- /pendulum suspension!

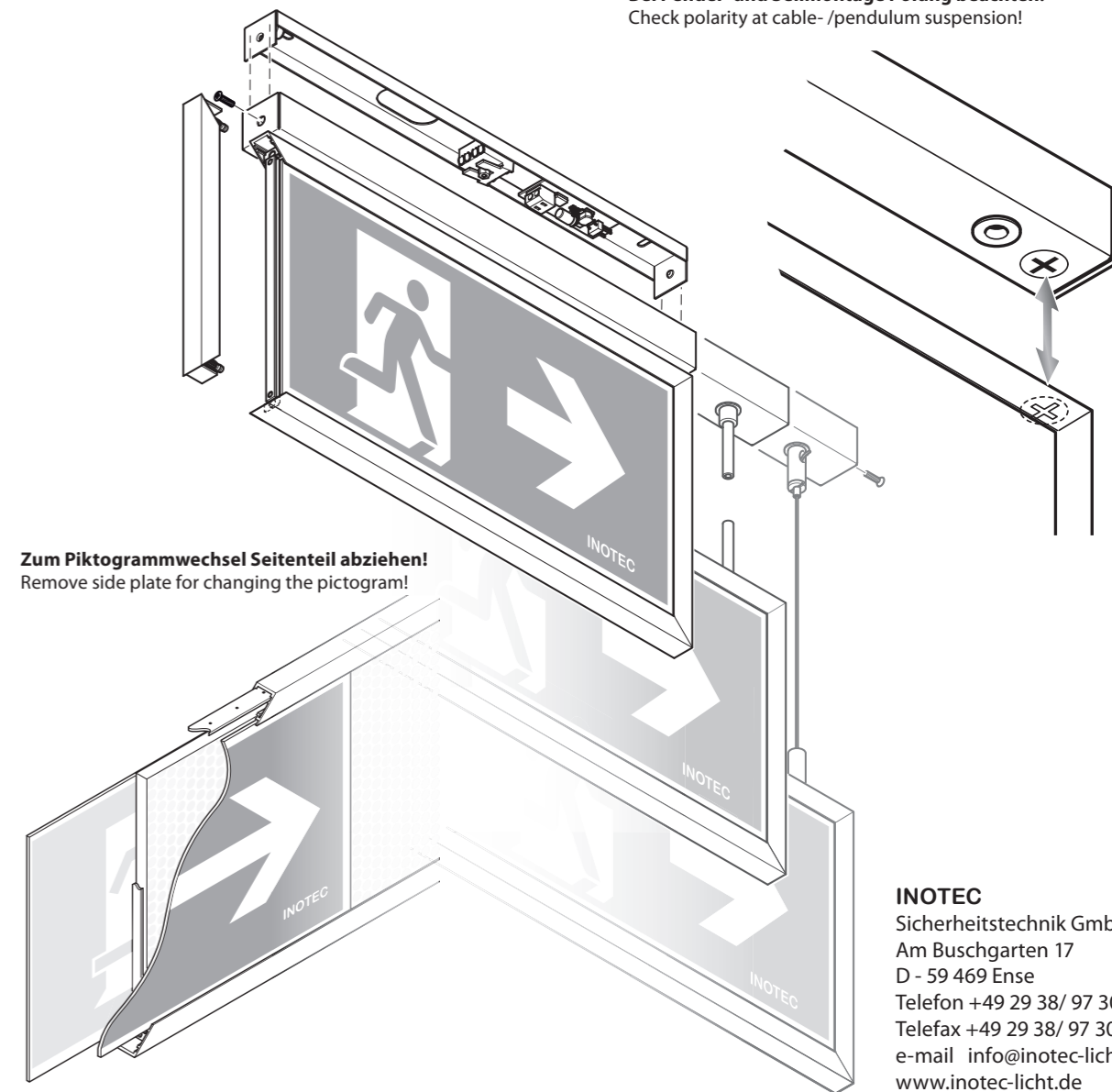

INOTEC
Sicherheitstechnik GmbH
Am Buschgarten 17
D - 59 469 Ense
Telefon +49 29 38/ 97 30 - 0
Telefax +49 29 38/ 97 30 - 29
e-mail info@inotec-licht.de
www.inotec-licht.de